

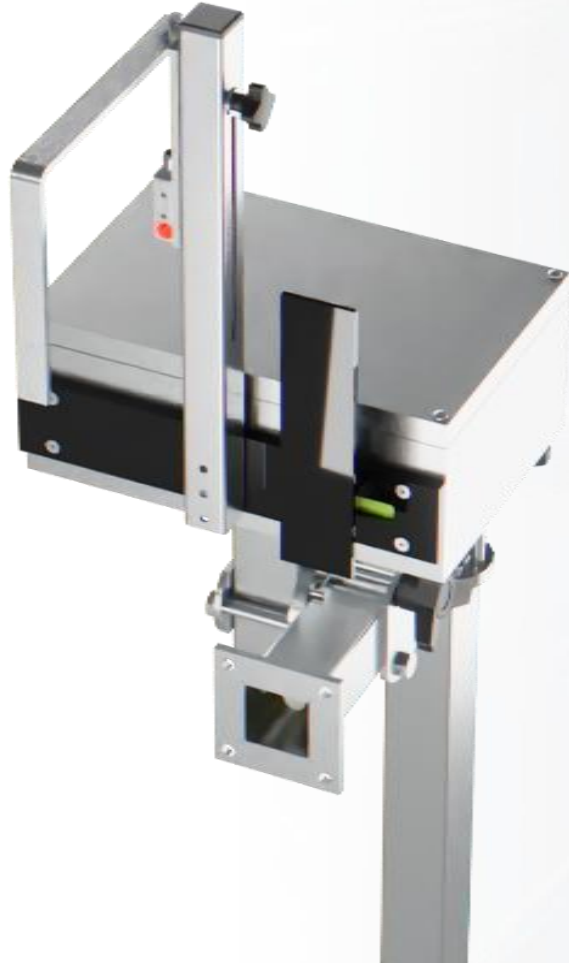

TLP
Servo Rejection System

Rejection System - TLP



A reliable and budget-friendly solution designed to automate the sorting process for various container formats in your production line.

This robust system ensures safe standing rejection, for slower speeds.

Features

- Ideal for glass bottles and PET applications
- Upright rejection onto a reject table
- Suitable for slow lines up to 40,000 BpS
- Budget-friendly application
- No height adjustment required
- Tracking by external shift register (tracking controller)



Benefits

Enhanced Production Efficiency

Boost productivity and streamline operations with the TLP Rejection System's automated sorting process, designed for a wide range of container formats.

Safe Standing Rejection

Ensure the safe and upright rejection of containers onto a reject table, even at high speeds and with small bottle spacing, reducing the risk of container damage and product loss.

Budget-Friendly Solution

Invest in an efficient and affordable sorting solution with the TLP Rejection System, specifically designed for slow lines up to 40,000 BpS.



Benefits

Easy Integration

Easily incorporate the TLP Rejection System into your existing production line without the need for height adjustments, thanks to its streamlined design.

Accurate Tracking

Benefit from precise container tracking with the TLP Rejection System's external shift register, ensuring efficient and accurate rejection.



Application

Suitable for sorting a variety of container formats, including:

- Glass bottles
- PET bottles
- Other container types (depending on size and shape)



Process

1. When a container is ready for rejection, the TLP Rejection System activates a following plate that moves in sync with the container, gently pushing it sideways.
2. The container is safely and securely guided by the following plate, maintaining an upright position throughout the process.
3. The rejected container is then smoothly transferred onto a reject table, where it can be collected and removed from the production line.

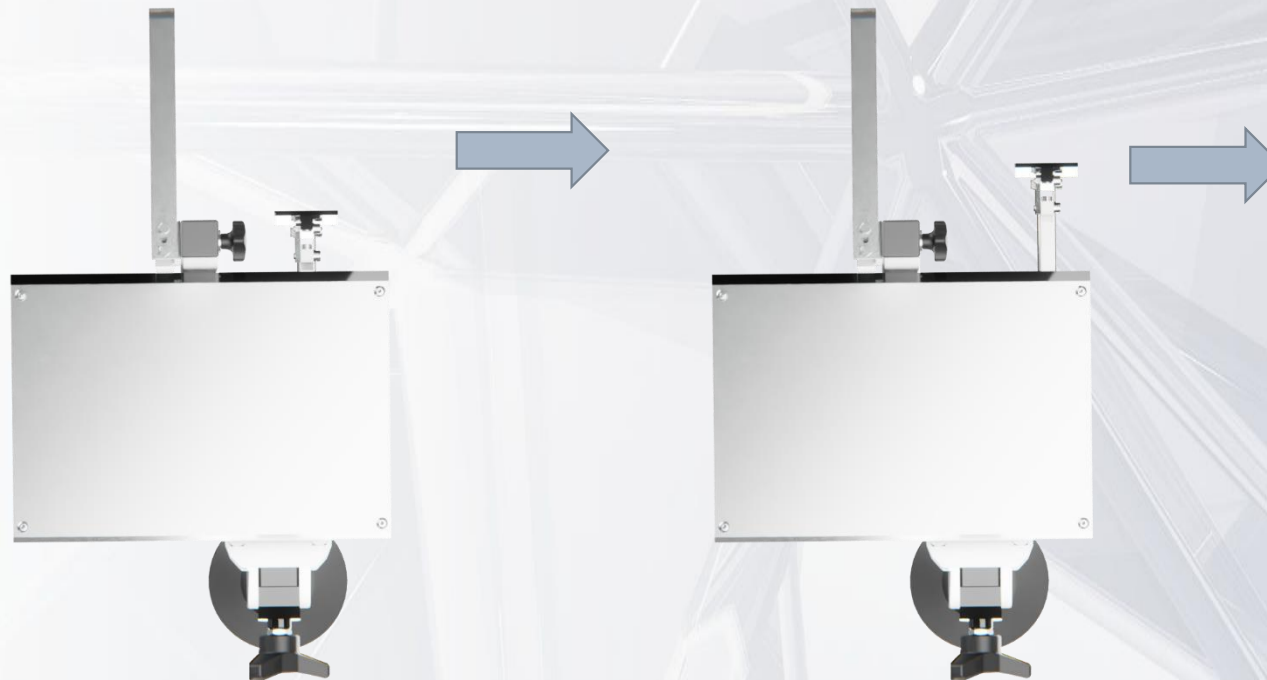

Specifications

TLP

- Up to **40,000** containers per hour
- Standing rejection & distribution
- Application for containers that are easy to tip over.
- Automatic adaptation to different belt speeds
- Ideal for open containers
- Tracking by external shift register (tracking controller)
- Retrofits & connection to third-party control systems possible
- Height adjustment (option)
- Horizontal adjustment available (option)

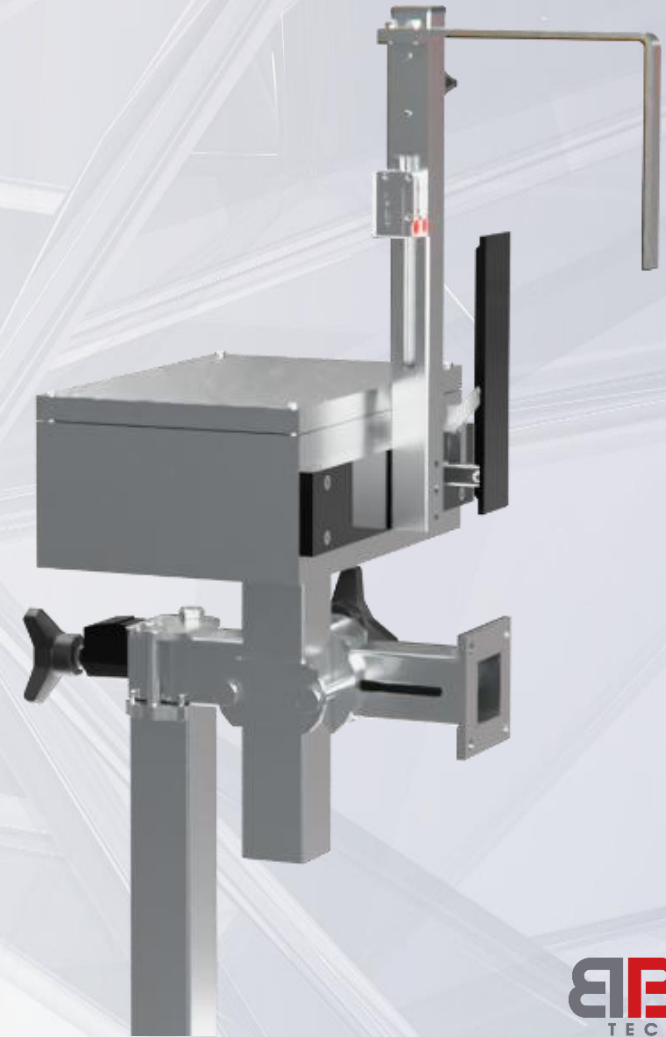

Warranty & Support

Our systems come with a comprehensive warranty and dedicated after-sales support services to ensure customer satisfaction and peace of mind.

- Contact us for more information on warranty coverage and available support services.



STRATEC CONTROL - SYSTEMS GmbH
Ankerstraße 73
75203 Königsbach-Stein
Telefon (+49) 72 32- 40 06- 0
Telefax (+49) 72 32- 40 06- 25
E-Mail: info@bbull.com
www.bbull.com

Take the Next Step! Request Further Information Today

Contact us to learn more about our system and how it can help your business succeed. Our team of experts is ready to answer any questions and provide you with a personalized solution.

Don't wait, make a call or send an email today and learn about the difference our system can make!

